



# INSTALLATION INSTRUCTIONS

Accessory

TRUNK SPOILER

Application

2008 CIVIC  
4-DOOR

Publications No.

All 37745

Issue Date

AUG 2007

## PARTS LIST

Trunk spoiler

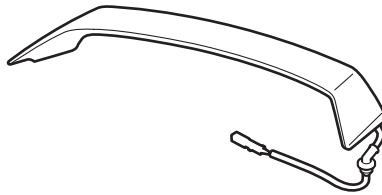

2 Cap nuts



2 Screws



Left trunk spring  
(marked yellow)

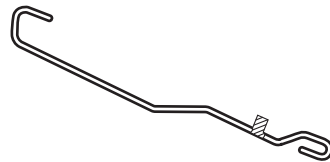

Right trunk spring  
(marked red)

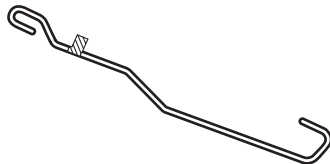

Spoiler harness



17 Wire ties

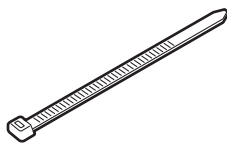

2 EPT Sealers

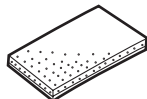

Template

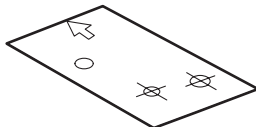

2 Protective tapes

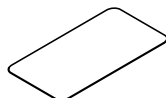

## TOOLS AND SUPPLIES REQUIRED

Phillips screwdriver

Shop towel

Small flat-tip screwdriver

Eye protection (face shield, safety goggles, etc.)

Drill

3 mm, 6 mm, 8 mm, and 10 mm Drill bits

Drill stop

10 mm Combination wrench

Felt-tip pen

Centerpunch

File

Touch-up paint

Hammer

10 mm Socket

Torque wrench

Heavy gloves

Clip remover

Trunk Spring Installation/Removal Tool

T/N 07AAF-SNA-A100

## INSTALLATION

**Customer Information:** The information in this installation instruction is intended for use only by skilled technicians who have the proper tools, equipment, and training to correctly and safely add equipment to your vehicle. These procedures should not be attempted by "do-it-yourselfers."

### NOTE:

- Be careful not to damage the body paint finish.
- This trunk spoiler kit should be installed only if the ambient air temperature is 60°F (15°C) or above.
- Wash and wax the area to be covered with a high quality paste wax.

### Installing the Rear Wing Spoiler

1. Make sure you have the anti-theft code for the radio, then write down the frequencies for the preset buttons.
2. Disconnect the negative cable from the battery.

- Open the trunk lid. If equipped, remove the hinge arm cover (two clips).

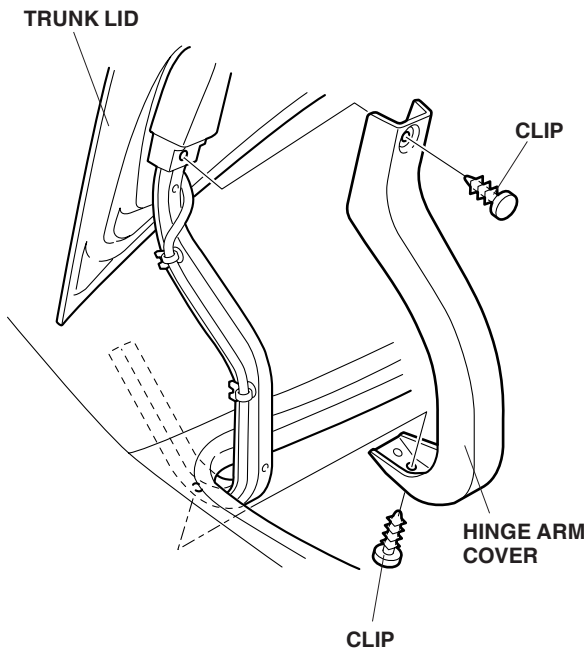

- If equipped, remove the trunk lid cover (eight clips).

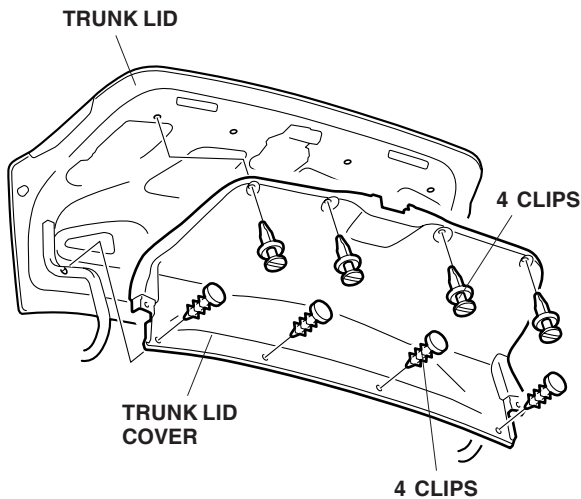

- On the inside of the trunk lid, locate the identification marks on the trunk lid. Lightly center-punch the mark. Repeat on the right side of the trunk lid.

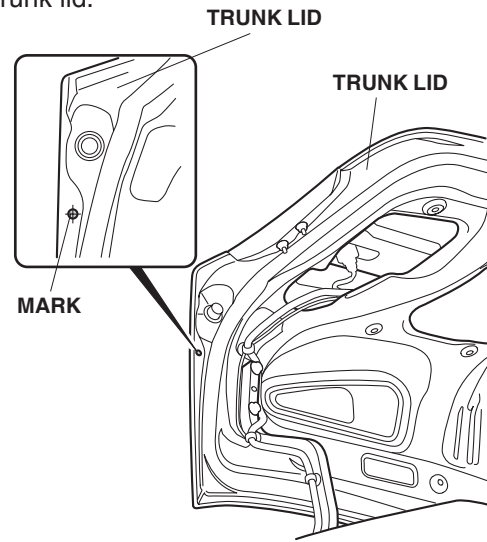

- While wearing eye protection, drill an 8 mm hole through each mark.

- To prevent the metal shavings from falling onto the trunk floor, place a cover over the trunk floor.
- First drill with a 3 mm drill bit, then finish with an 8 mm drill bit.
- Remove all burrs and metal shavings, and apply touch-up paint to the edges of the holes.
- When the touch-up paint is dry, clean the area to be covered, and wax it with a high-quality paste wax.
- Repeat on the right side of the trunk lid.

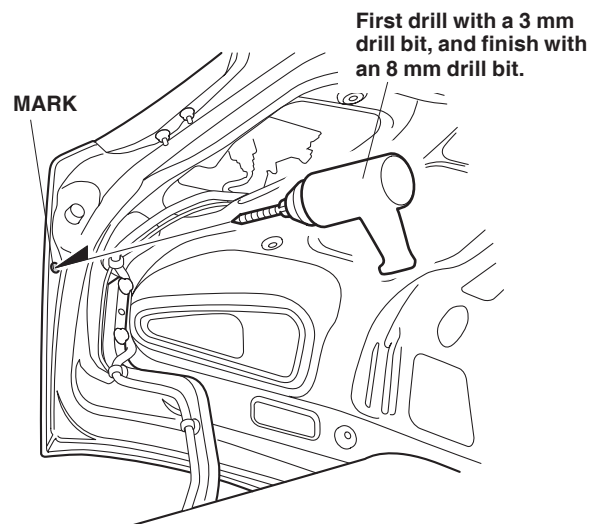

7. Mark the trunk lid stopper with a felt-tip pen, then turn it counterclockwise to remove it. Repeat on the opposite side.

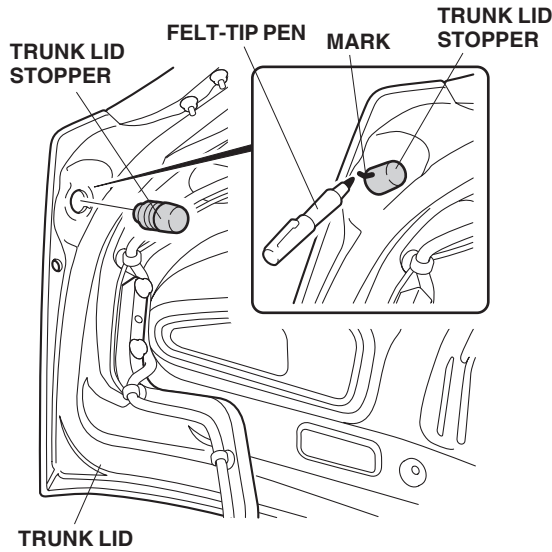

8. Close the trunk lid. Position the template, printed side up, at the left (driver's side) edge of the trunk lid. Align the front hole in the template with the hole in the trunk lid. Using a felt-tip pen, mark the trunk lid as indicated on the template (two marks on the left side).

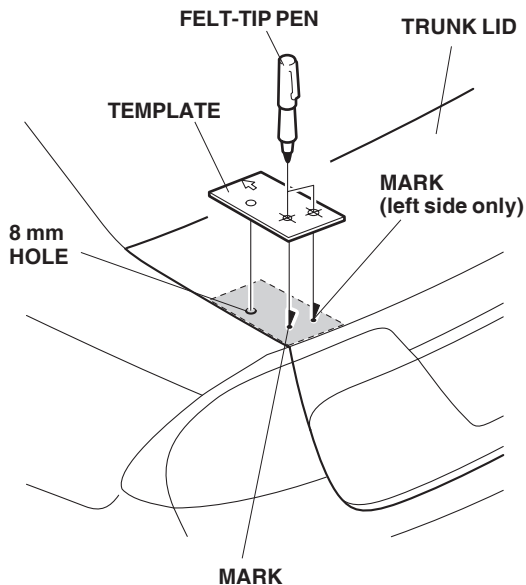

9. Remove the template, and lightly center-punch the mark.
10. Repeat steps 8 and 9 on the right side.

The right side of the trunk lid does not need a inner hole; mark only the outer side.

11. While wearing eye protection, drill one 10 mm hole and one 8 mm hole at the center-punched marks through the outer skin of the trunk lid. Use a drill stop to avoid drilling through the inner panel.

- When drilling a 10 mm hole, first drill with a 3 mm bit, then with a 6 mm bit, and finish with a 10 mm bit.
- When drilling a 8 mm hole, first drill with a 3 mm bit, then with a 6 mm bit, and finish with a 8 mm bit.
- Remove all burrs and metal shavings, and apply touch-up paint to the edge of the hole you drilled.

NOTE: Left rear side hole is for routing the spoiler harness through the trunk lid.

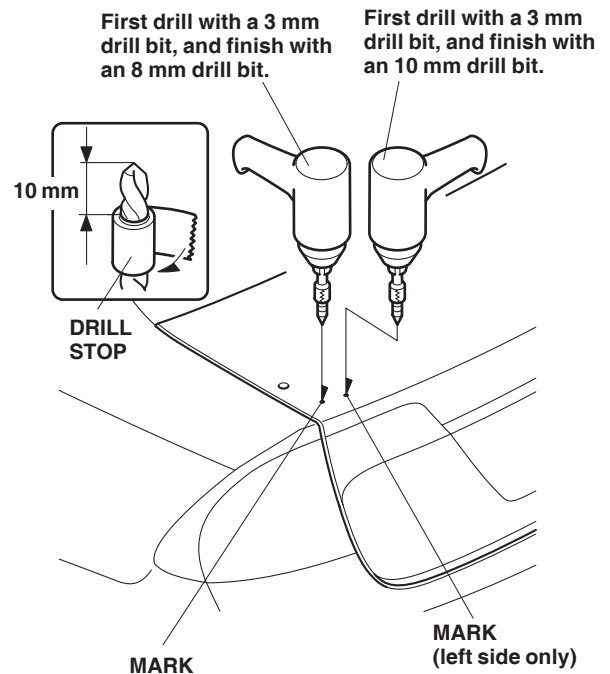

- Open the trunk lid. Route the harness of the trunk spoiler down through the 10 mm hole you just drilled. Attach the grommet of the trunk spoiler harness to the 10 mm hole.

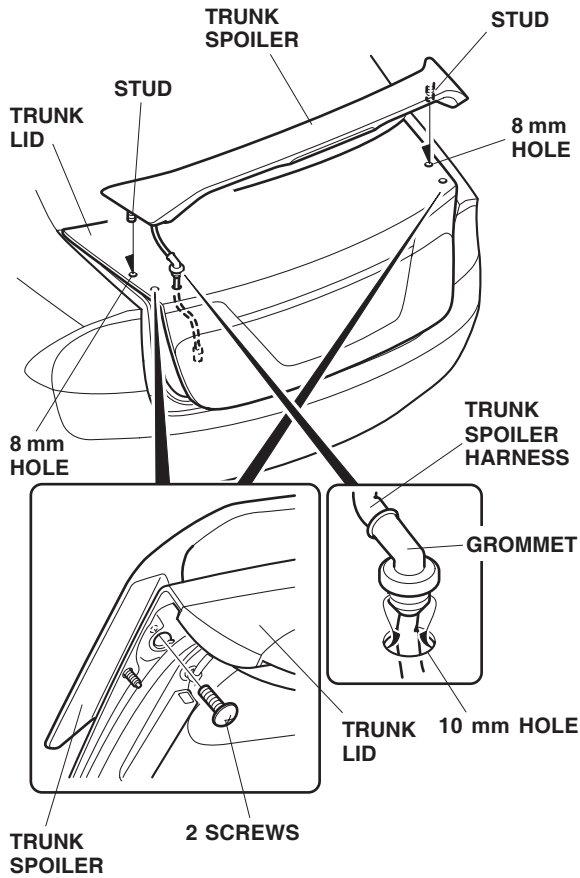

- Using isopropyl alcohol on a shop towel, thoroughly clean the areas where the trunk spoiler will attach. Fit two studs on the trunk spoiler into the created two 8 mm holes, tentatively secure with two screws, and check the hole position.
  - Take care not to drop the screws in the trunk lid.
  - If the holes do not align, remove the trunk spoiler and enlarge the holes with a file. Apply touch up paint if needed. After the paint has dried, perform steps 12 and 13 again.

- Remove the two adhesive backings from the trunk spoiler.

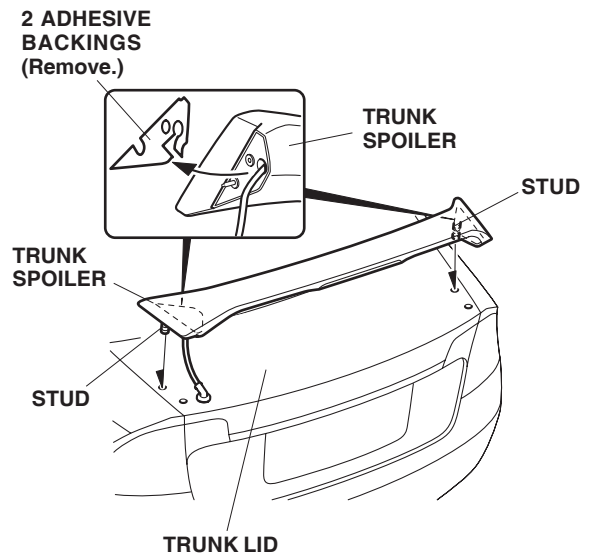

- Position the trunk spoiler on the trunk lid by inserting the studs into the holes in the trunk lid.
- Hold the spoiler firmly against the trunk lid over the adhesive tapes with the palm of your hand.
- Open the trunk lid. Position the trunk spoiler onto the trunk lid and install the two screws and two cap nuts.
  - Torque the screws to 3.9 N·m (0.4 kgf·m, 2.9 lb-ft).
  - Torque the cap nuts to 8.8 N·m (0.9 kgf·m, 6.2 lb-ft).
  - Take care not to drop the screws in the trunk lid.

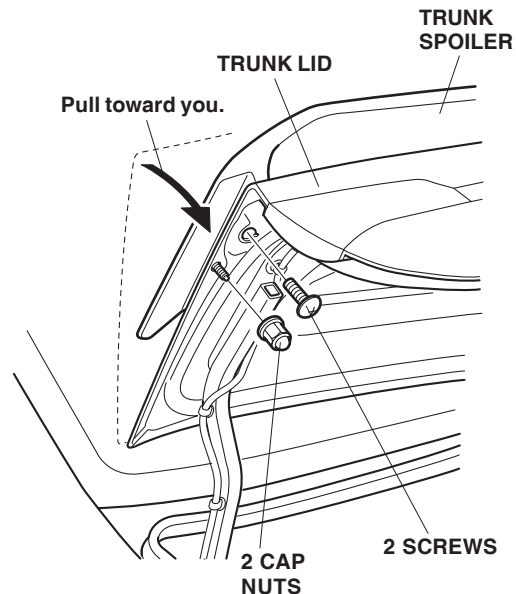

## Installing the Trunk Spring

18. Open the trunk lid, and remove the center clip from the trunk springs.

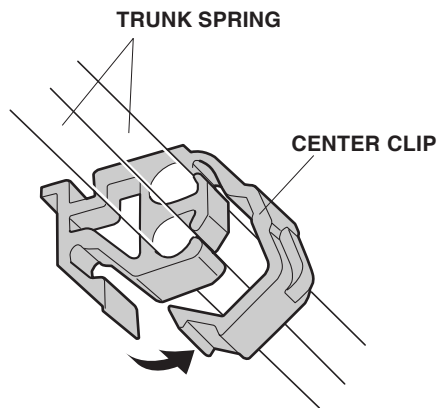

19. With an assistant holding the trunk lid open, remove the old trunk springs from the trunk hinge arms using the special tool. Wear gloves to protect your hands, and pull the special tool slowly and carefully toward you.

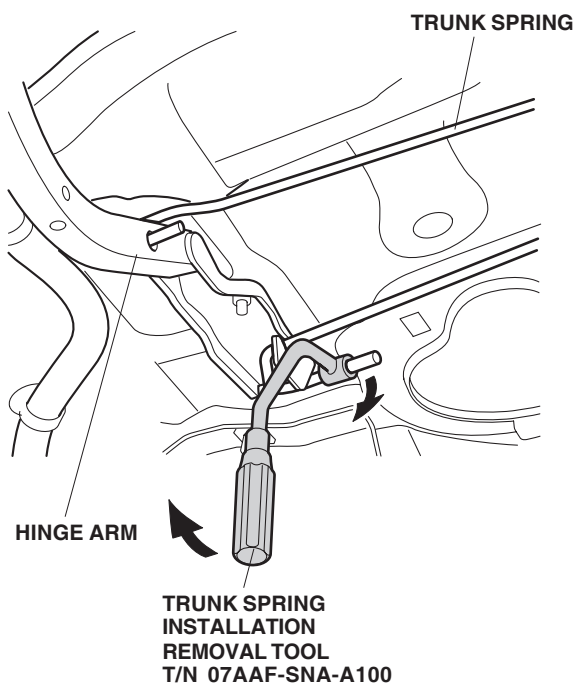

20. Using the trunk spring installation/removal tool, install the right trunk spring and the left trunk spring :
- Set the tool on the marked end of each trunk spring.
  - Install the red-marked spring in the slot in the right (passenger's) side trunk hinge arm and into the hinge bracket on the left (driver's) side of the vehicle; install the yellow-marked spring in the slot in the left (driver's) side trunk hinge arm and to the hinge bracket on the right (passenger's) side of the vehicle.
  - Wearing gloves, rotate the tool as you pull it toward you.
  - Set the springs in the first notch of the hinge brackets if the vehicle is not equipped with a trunk liner; set the springs in the second notch of the trunk liner if the vehicle is equipped with a trunk liner.
  - Reinstall the center clip on the trunk springs.

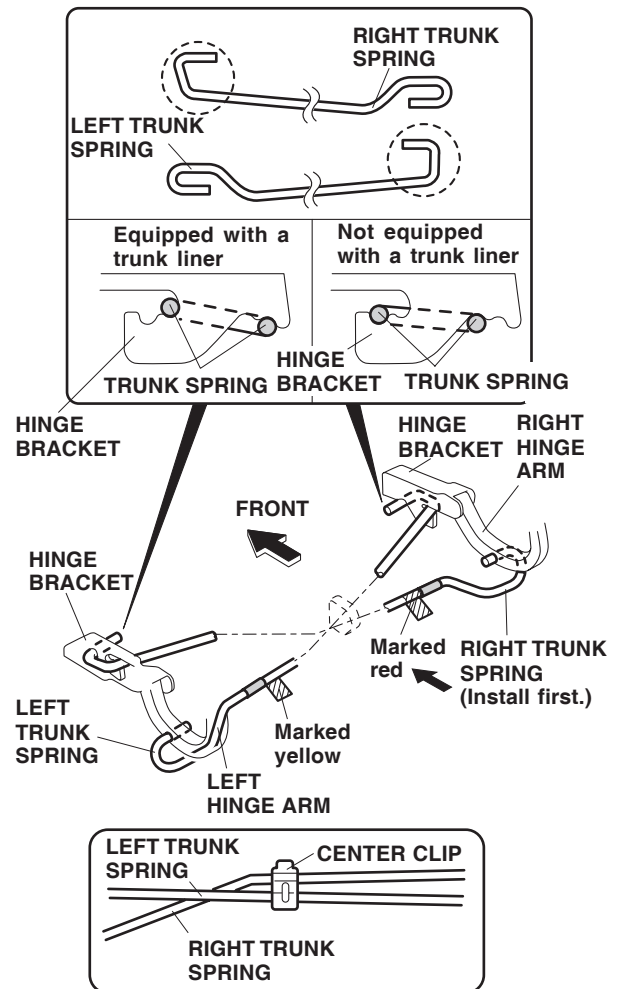

## Routing the Wire Harness

21. When the vehicle is equipped with the left hinge arm cover, cut off the seven ribs of the left hinge arm cover as shown.

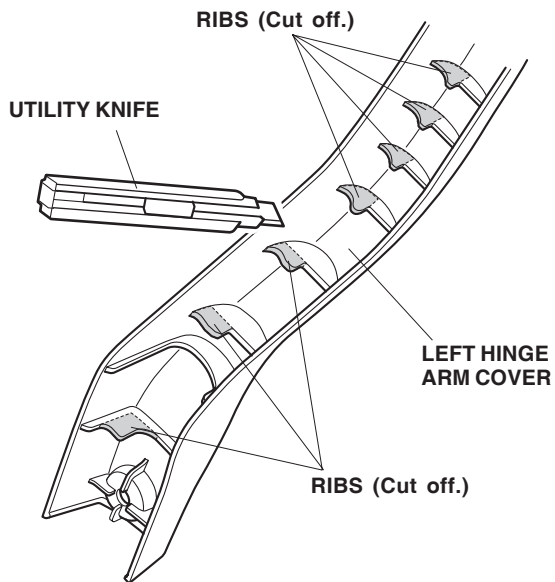

22. Remove the left side trunk lining (two clips).

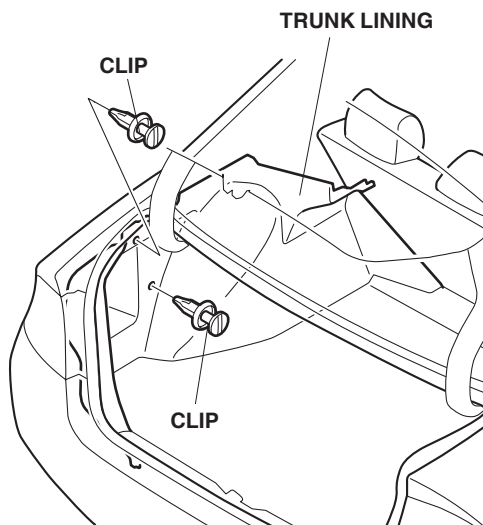

If the bass system is not mounted on the car, go to step 23. If the bass system is mounted, go to step 25.

*If the bass system is not mounted on the car:*

23. Unplug the 2-pin connector of the high-mount brake light from the rear metal shelf.

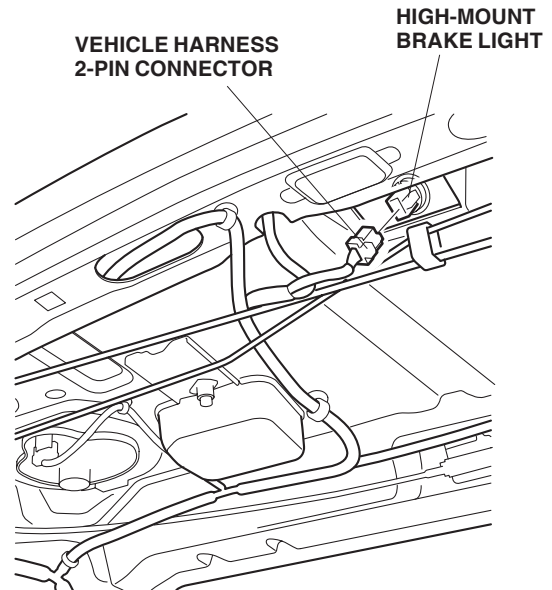

24. Route the vehicle harness 2-pin connector above the trunk springs, and plug it into the spoiler harness 2-pin connector. Secure the 2-pin connector to the vehicle harness with one wire tie in the area shown. Then, go to step 26.

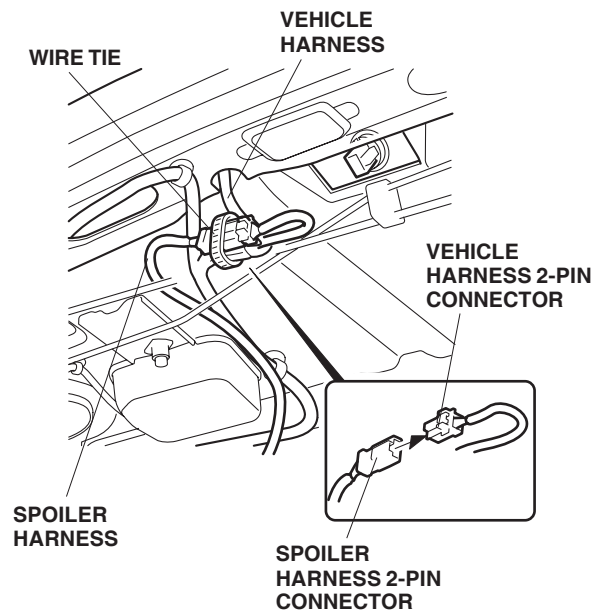

***If the bass system is mounted on the car:***

- Unplug the 2-pin connector of the bass system cable from the rear metal shelf. Plug the bass system cable 2-pin connector into the spoiler harness 2-pin connector. Secure the 2-pin connector to the vehicle harness with one wire tie in the area shown.

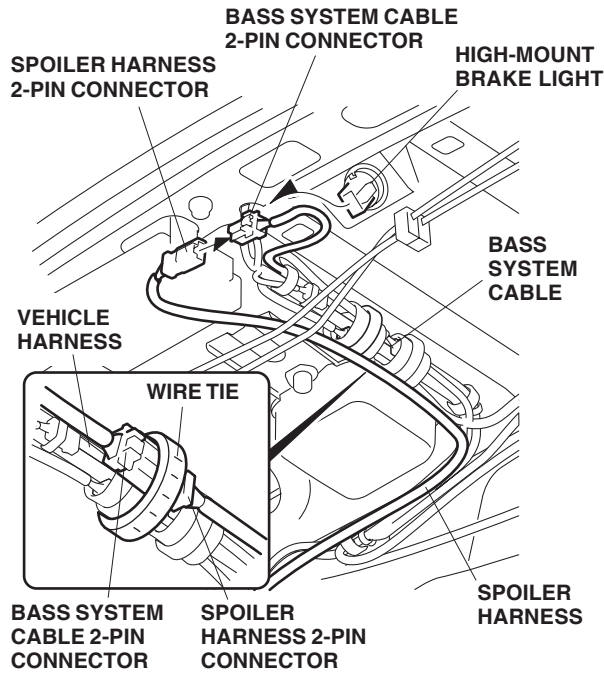

- Gently pull down the right trunk panel, and locate the clip on the vehicle harness attached to the rear metal shelf. Align the green tape on the spoiler harness with the clip on the vehicle harness, and secure the spoiler harness to the vehicle harness with one wire tie in that area.

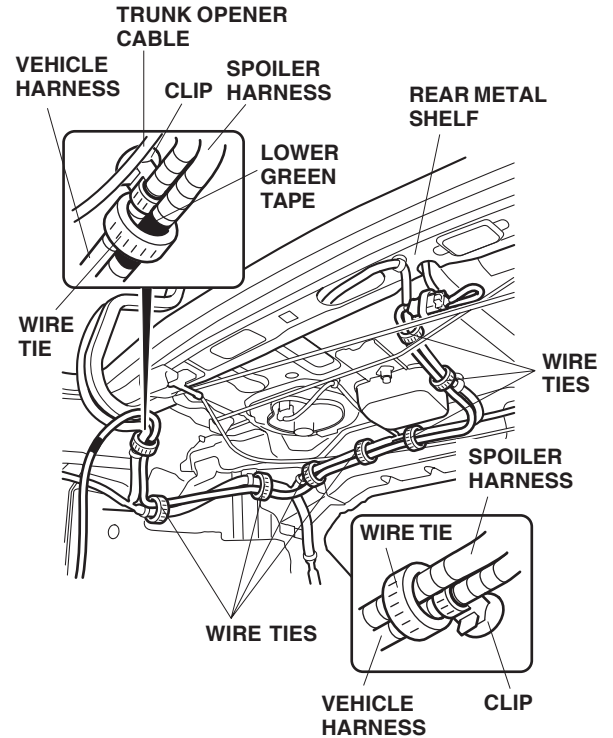

- Route the spoiler harness alongside the vehicle harness, and secure it with seven wire ties in the area shown.

28. Continue routing the spoiler harness up the trunk arm and alongside the vehicle harness.

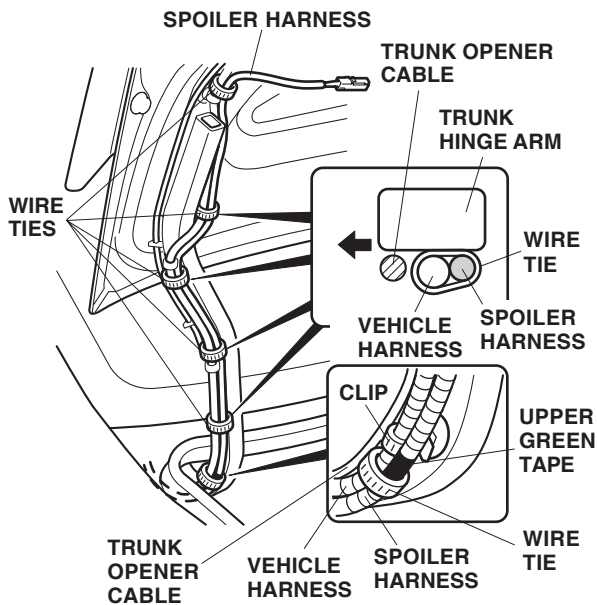

29. Align the upper green tape on the spoiler harness with the upper clip on the vehicle harness, and secure the spoiler harness to the vehicle harness with one wire tie in the area shown. Do not secure the wire tie on the trunk opener cable.
30. Secure the spoiler harness with five wire ties in the area shown. Do not secure the wire tie on the trunk opener cable.

31. Using scissors, cut one EPT sealer in half horizontally. Wrap the one half of EPT sealer around the trunk spoiler harness in the areas shown.

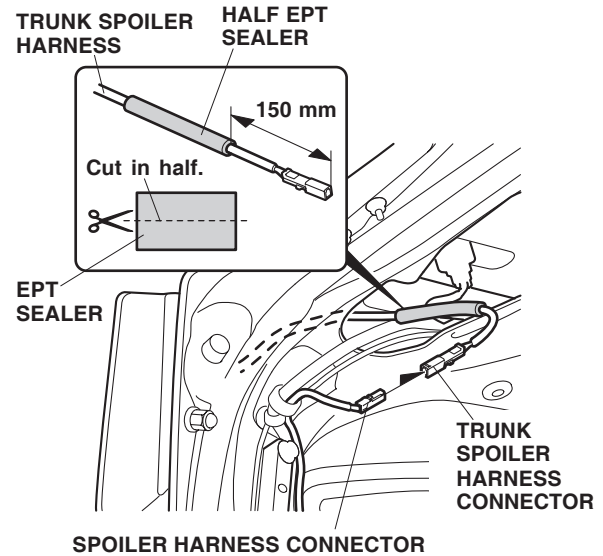

32. Plug the spoiler harness connector into the trunk spoiler harness connector.
33. Wrap the connectors with EPT seal.

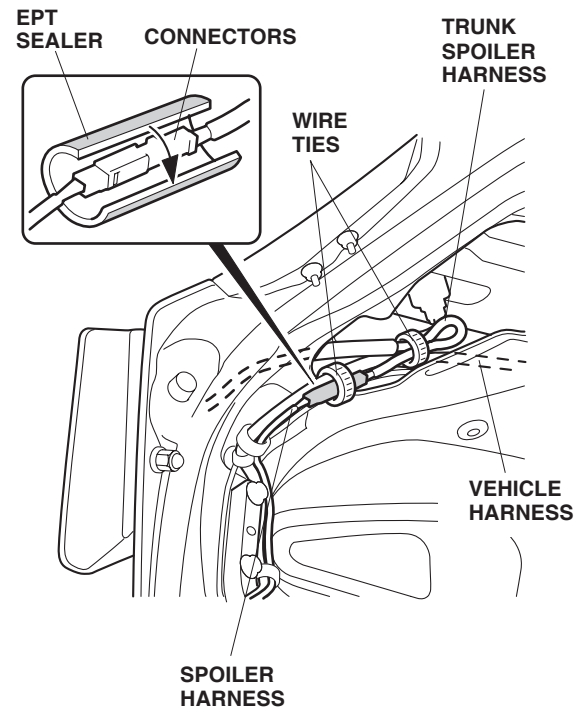

34. Make loops in the trunk spoiler harness, then secure the trunk spoiler harness and spoiler harness to the vehicle harness with the two wire ties as shown.



35. Remove the adhesive backing from each of the protective tapes, and attach the protective tapes to the rear bumper as shown.

NOTE: The protective tapes are designed to protect the rear bumper from being hit by the trunk lid when it is closed. Be sure to attach the protective tapes in the specified positions securely.

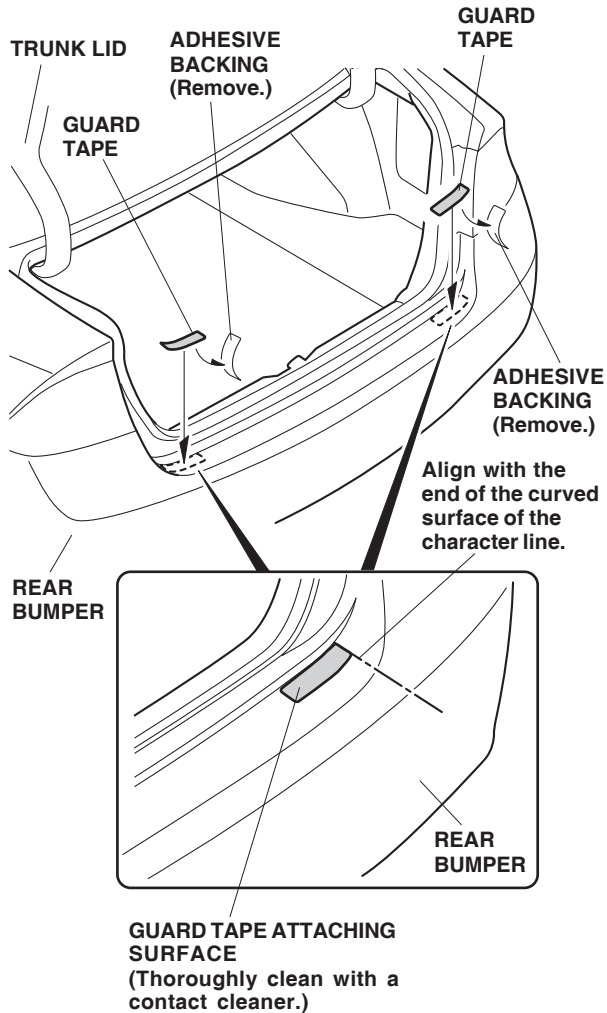

36. Open the trunk lid, and make sure the trunk lid stays open on its own. If it does not, adjust the trunk springs to the second position.
37. Check that all wire harnesses are routed properly and that all connectors are plugged in.
38. Reconnect the negative cable to the battery.
39. Enter the customer's radio anti-theft code, and reset the radio station presets.
40. Reset the clock.
41. Press the brake pedal, and check that the spoiler brake light comes on.
42. Reinstall all removed parts.

NOTE: When the battery is disconnected, the driver's window AUTO function is disabled.

- Start the engine. Push down on the driver's window switch until the window is fully open.
- Pull up on the driver's window switch to close the window completely, then hold the switch for 2 seconds or more.
- Lower and raise the driver's window to check operation of the driver's window AUTO function.

#### USE AND CARE

- Handle the spoiler with care. It is not designed to absorb impact.
- Do not open or close the trunk lid by grasping the spoiler.
- Check the spoiler mounting nuts periodically, and retighten them if necessary.