



INSTALLATION INSTRUCTIONS

Accessory

BACKUP SENSOR

Application

2006 PILOT

Publications No.

All 30477

Issue Date

SEP 2005

PARTS LIST

Backup Sensor Attachment Kit (sold separately)
P/N 08V67-S9V-100A

Control unit

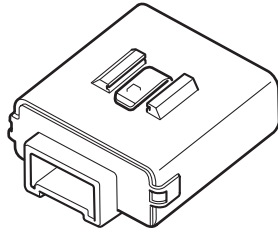

Beeper

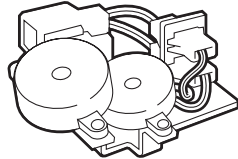

Backup sensor harness

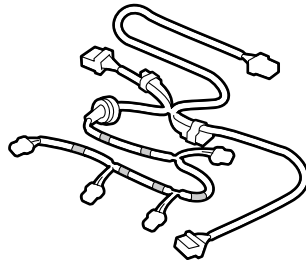

Control unit bracket

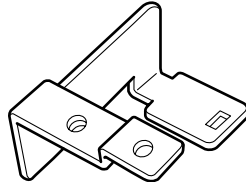

Flange bolt



2 Clips



Fuse label

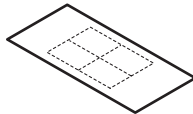

4 Cushion tapes

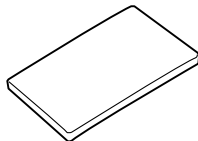

12 Wire ties

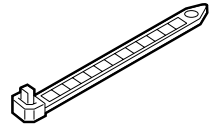

4 Wire ties with clip

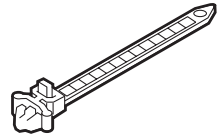

Double-sided adhesive tape

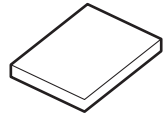

Switch

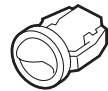

Pillar clip



Owner's Manual

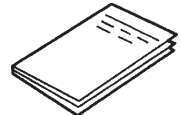

Backup Sensor Kit (sold separately)

2 Corner sensors

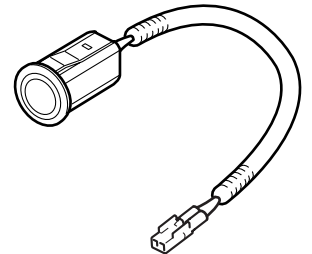

2 Center sensors

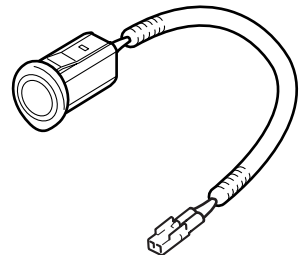

2 Spacers

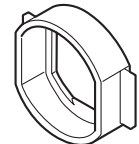

TOOLS AND SUPPLIES REQUIRED

Phillips screwdriver
Flat-tip screwdriver
Small flat-tip screwdriver
Ratchet
10 mm, 12 mm, and 14 mm Sockets
Torque wrench
Diagonal cutters
Utility knife
Pushpin
Drill
20 mm, 22 mm and 26 mm Holesaw
Masking tape
Felt-tip pen
Tape measure
Isopropyl alcohol
Shop towel
Eye protection (safety goggles, face shield, etc.)
10 mm Combination wrench
Blanket
File

Illustration of the Backup Sensors Installed on the Vehicle

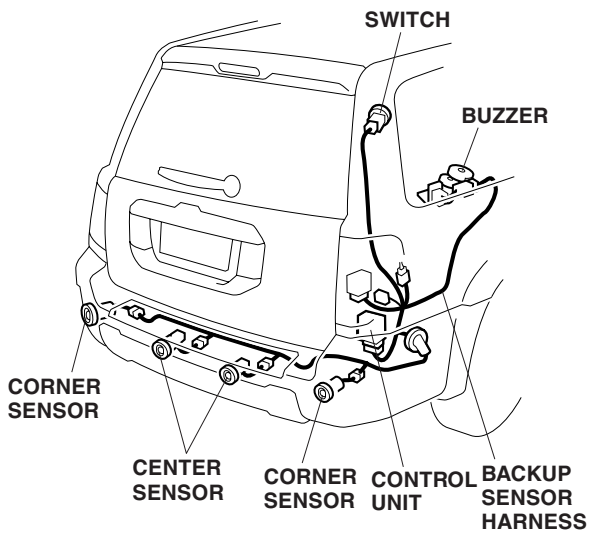

INSTALLATION

Customer Information: The information in this installation instruction is intended for use only by skilled technicians who have the proper tools, equipment, and training to correctly and safely add equipment to your vehicle. These procedures should not be attempted by “do-it-yourselfers.”

1. Make sure you have the anti-theft code for the radio, then write down the frequencies for the preset buttons.
2. Disconnect the negative cable from the battery.
3. Open the tailgate, and remove the rear cargo floor lid.

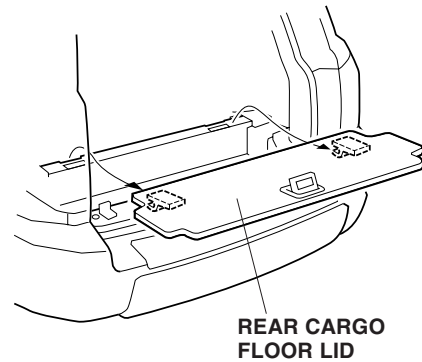

4. Pull away the weatherstrip from the tailgate opening, and remove the rear trim panel (four clips and six retaining tabs).

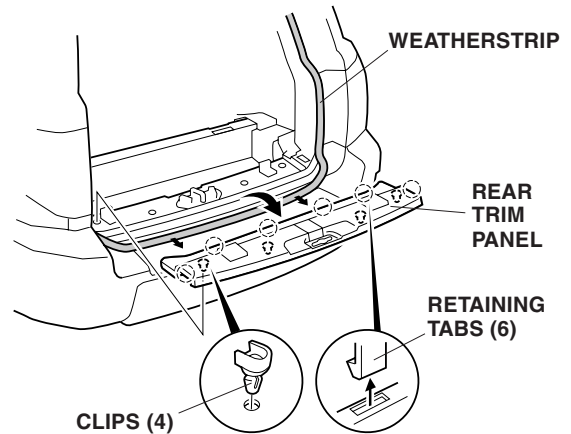

Installing the Sensors in the Bumper

- Remove the two short self-tapping washer-screws, four self-tapping screws, two long self-tapping washer-screws, two washer-screws, four clips and five bolts that secure the rear bumper. Slide the rear bumper out to release the two fender clips. Set the bumper on a blanket.

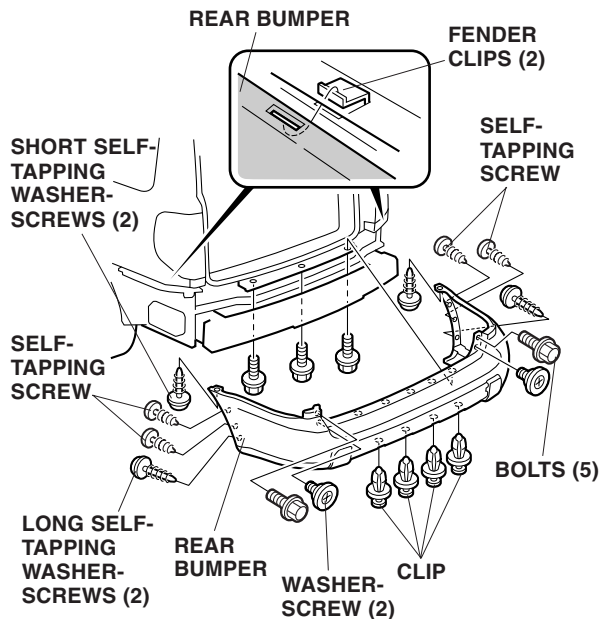

- Remove the bumper absorber. On the bottom edge of the bumper absorber, measure in about 365 mm and locate the rib. Using a utility knife, cut out the bottom of the bumper absorber in the areas shown.

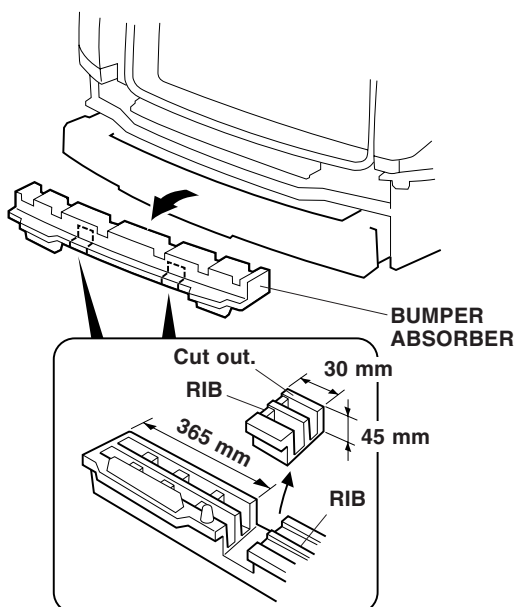

- On the inside of the rear bumper, locate the four marks. Using a pushpin, pierce through the rear bumper at each of the four marks.

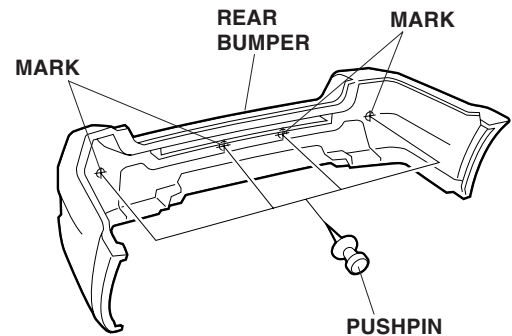

- While wearing eye protection, drill a 22 mm hole through each of the two outer marks, and a 26 mm hole through each of the inner marks. Remove any burrs from the edges of the holes.

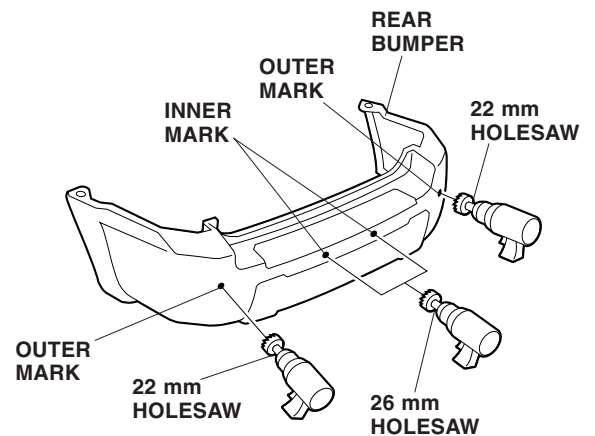

- Install the two corner sensors and the two center sensors into the rear bumper with the arrow on each sensor facing up. Do not push the microphone part of the sensor.

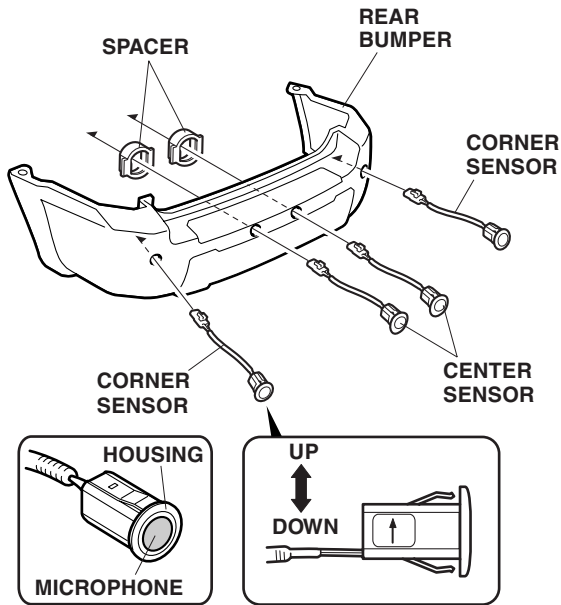

- Install one spacers to each center sensor from the inner side of the rear bumper.

Routing the Backup Sensor Harness

- Using a small flat-tip screwdriver or the ignition key, release the seat belt lower hook from the right third seat.

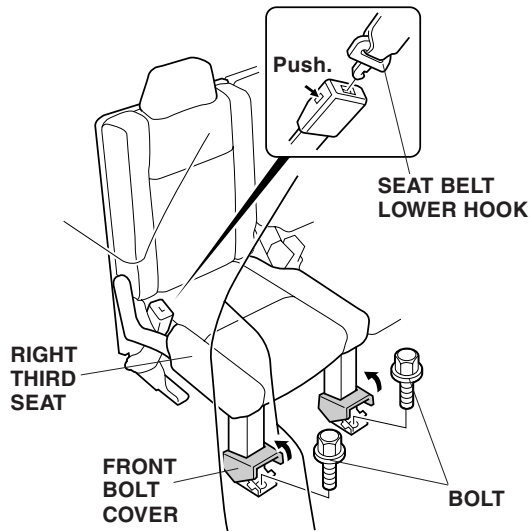

- Raise the front bolt covers on the right third seat, and remove the two bolts concealed under the covers.

- Raise the right third seat cushion, and remove the four bolts that fasten the rear right third seat to the floor. Remove the right third seat.

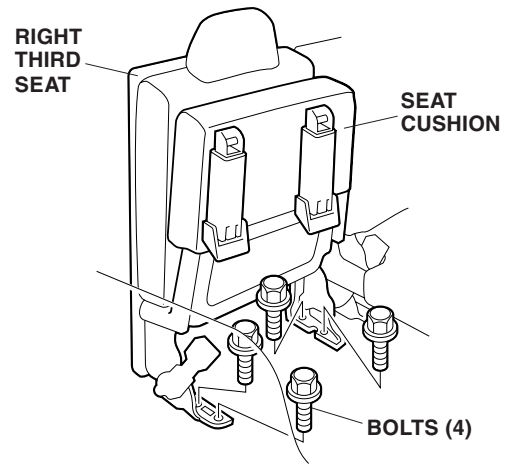

- On the right quarter pillar trim, remove the anchor bolt cover from the seat belt anchor, and remove the bolt that secures the seat belt anchor.

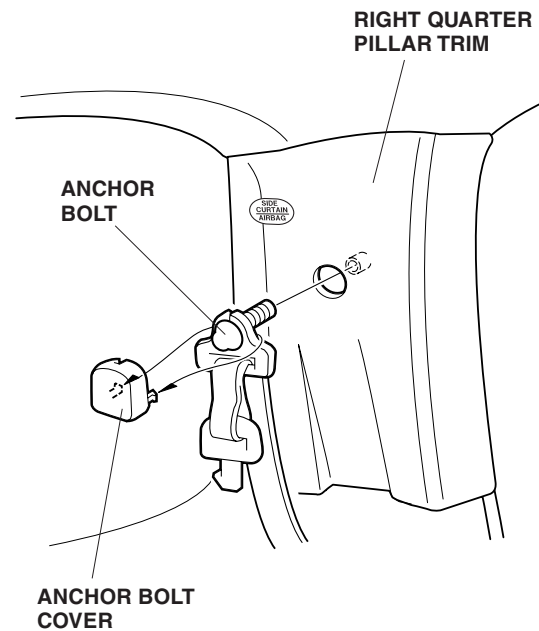

15. Using a small rubber mallet and a shop towel, gently tap the right quarter pillar trim at the area marked "SIDE CURTAIN AIRBAG" to release the clip.

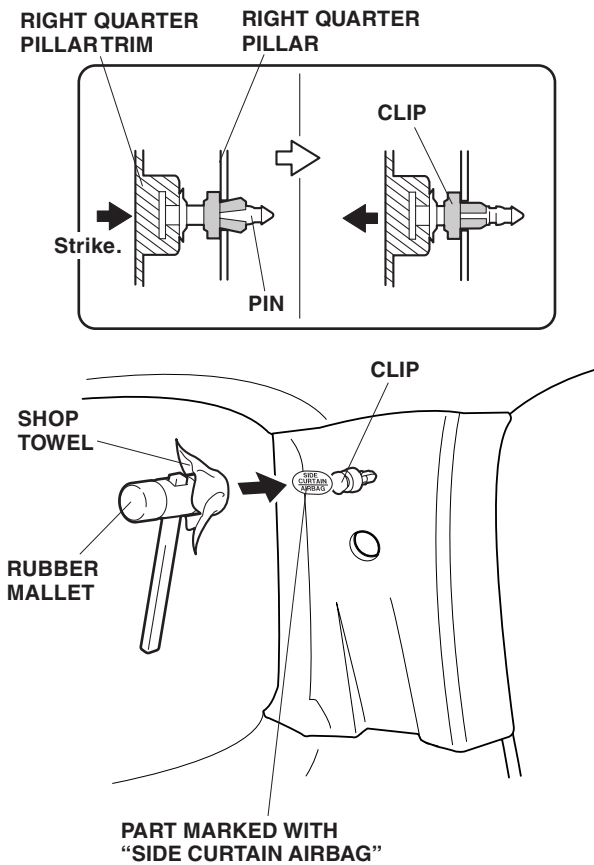

16. Remove the right quarter pillar trim (three clips and two retaining tabs).

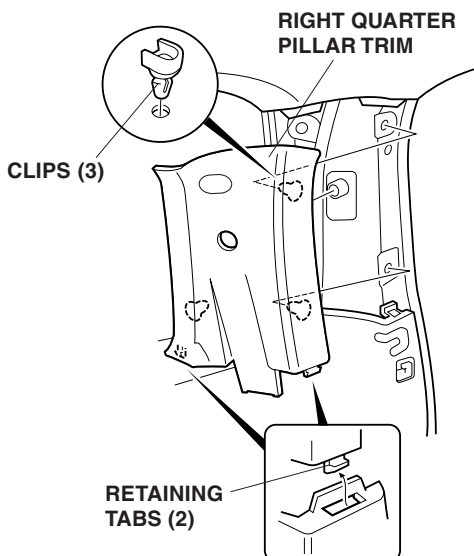

17. Remove and discard the clip from the right quarter pillar trim, and install the new pillar clip on the right quarter pillar trim.

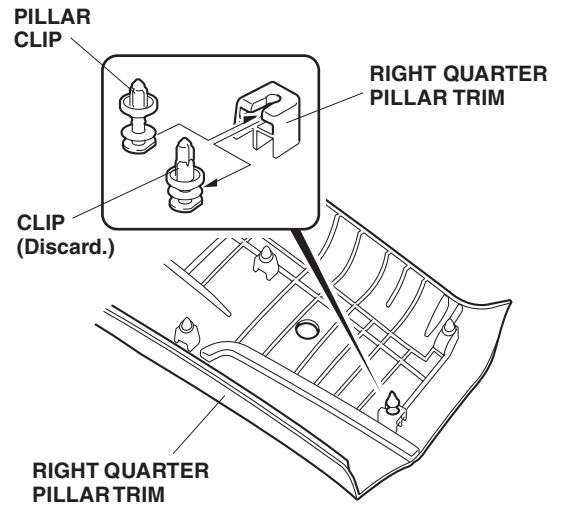

18. Pull away the door weatherstrip around the right rear door side sill. Remove the right rear door side sill (three clips and one retaining tab).

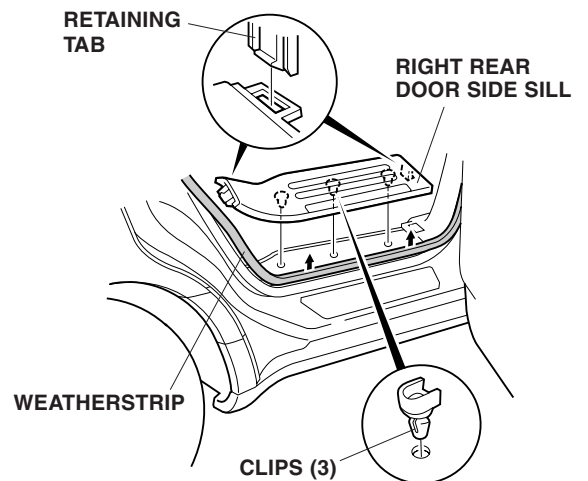

19. Remove the three tie-down hooks (one screw for each). Remove the two floor clips.

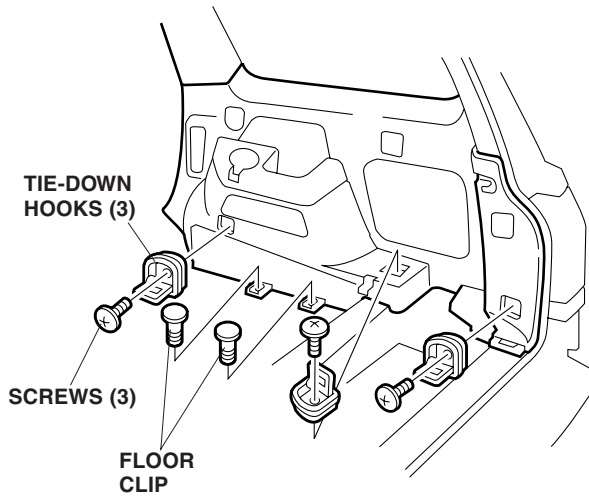

20. Remove the large plastic cover, and remove the screw concealed under the cover. Pry out the two small plastic covers, and remove the self-tapping screws. Tilt the cargo net hooks down, and remove the two self-tapping screws.

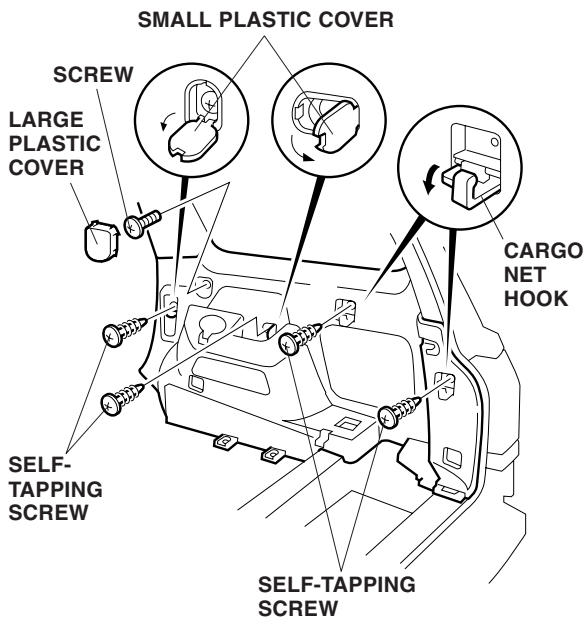

21. Pull away the tailgate weatherstrip in the area shown. Remove the six clips and three retaining tabs, unplug the vehicle connector from the rear sensor, and remove the right rear side panel.

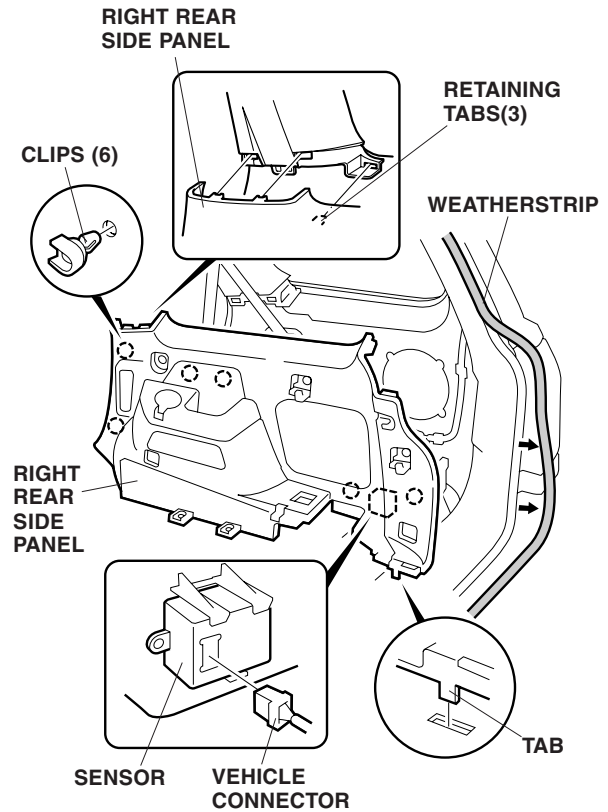

22. Lift the rear cargo box to release the three clips. While lifting the right side of the rear cargo box, remove and discard the insulator from the rear inside panel.

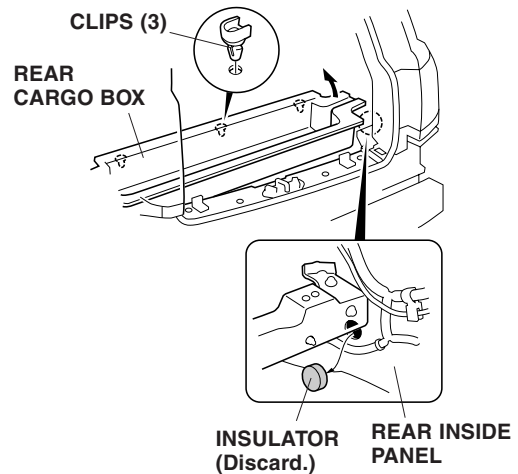

23. On the outside of the vehicle, remove and discard the front grommet from the rear panel.

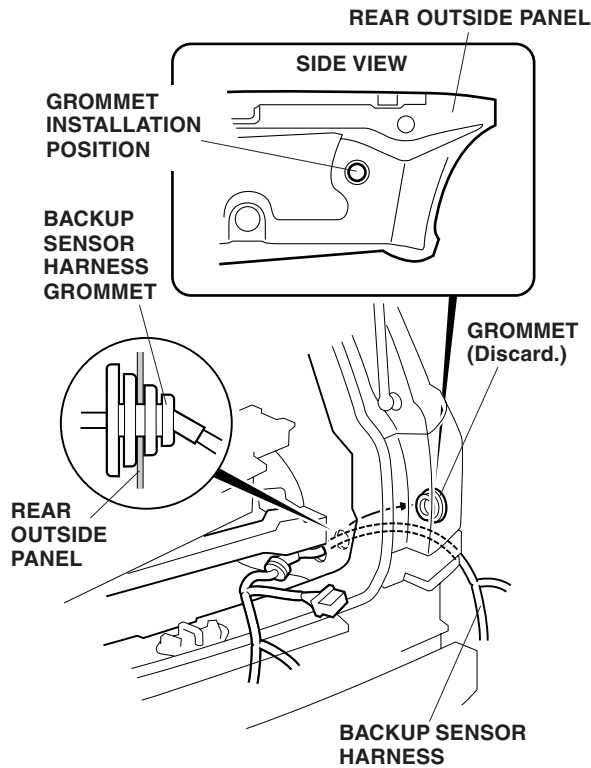

24. Pull the four backup sensor harness 2-pin connectors out through the grommet hole. Seat the backup sensor harness grommet in the grommet hole of the rear **outside** panel. Rotate the grommet so the wires face down.

25. Attach the two clips to the backup sensor harness at the green tape. Remove the two self-tapping screws from the vehicle, and secure the clips with these self-tapping screws.

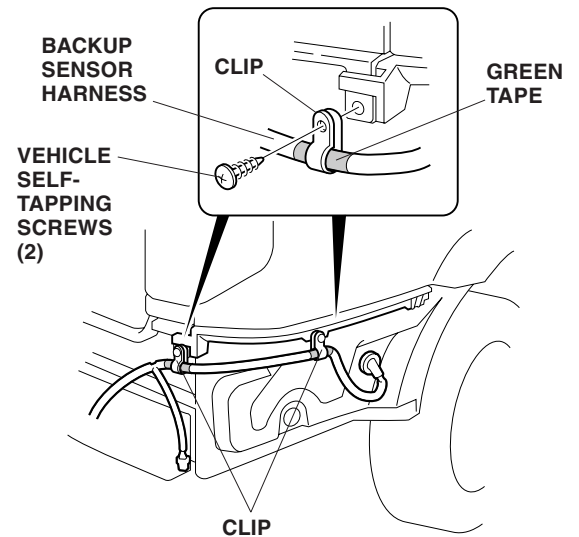

26. Attach the four wire ties with clip to the backup sensor harness where the green tape is located, then push the clips into the holes from the back side of the bumper beam and body frame.

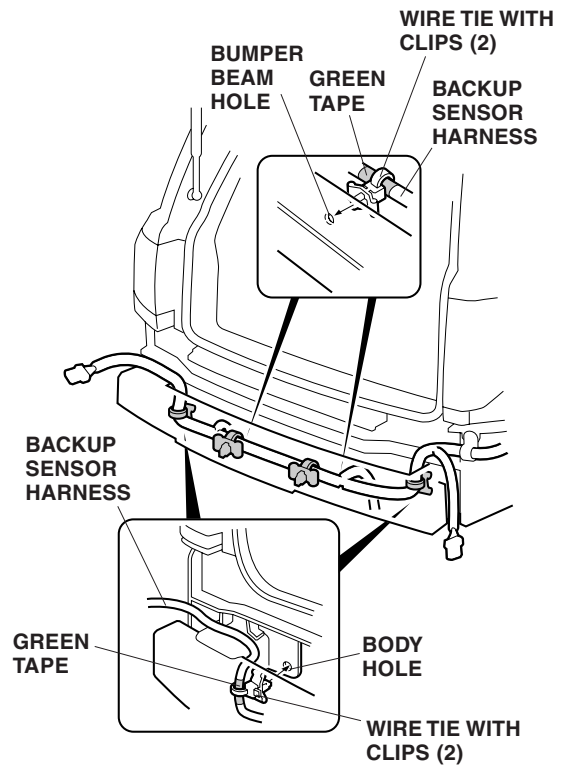

27. Slide the control unit bracket onto the control unit.

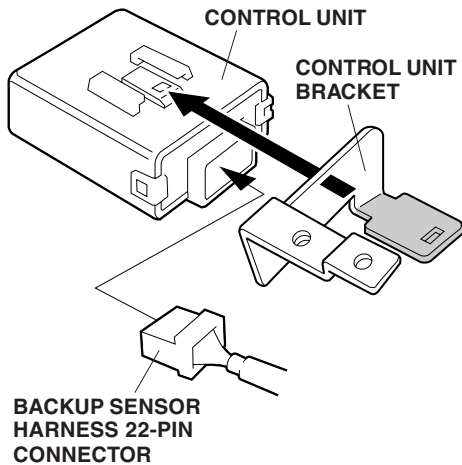

28. Plug the backup sensor harness 22-pin connector into the control unit.

29. Lift the right side of the rear cargo box, and position the control unit bracket on the body frame. Attach the control unit to the body frame using the flange bolt supplied.

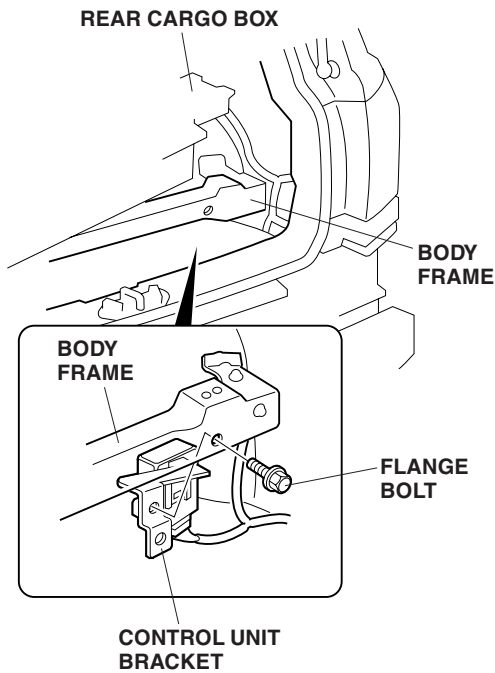

30. Secure the backup sensor harness to the vehicle harness with one wire tie in the area shown.

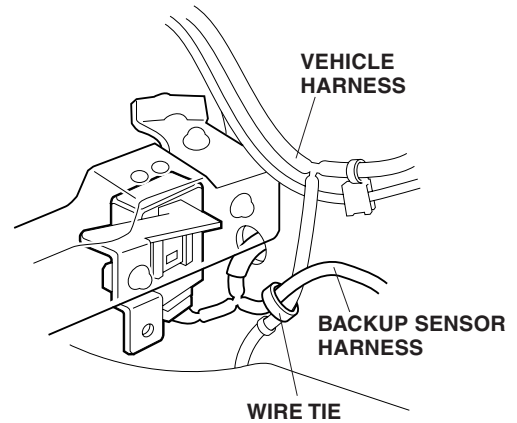

31. Reinstall the rear cargo box.

32. Using isopropyl alcohol, thoroughly clean the beeper bracket where the double-sided adhesive tape will attach. Remove one adhesive backing from the double-sided adhesive tape and attach the tape to the beeper bracket.

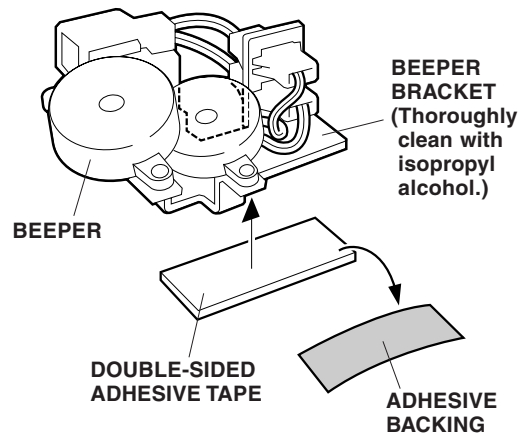

33. Using isopropyl alcohol on a shop towel thoroughly clean the inside rear panel where the beeper will attach. Remove the adhesive backing from the double-sided tape on the beeper, and attach the beeper to the inside rear panel. You **must** have 5 mm of clearance between the 5-pin connector and the inside rear panel.

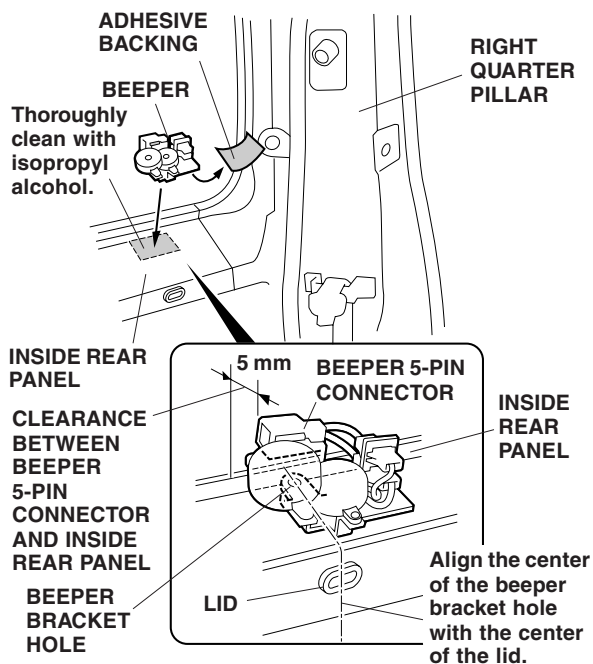

34. Plug the backup sensor harness 5-pin connector into the beeper 5-pin connector.

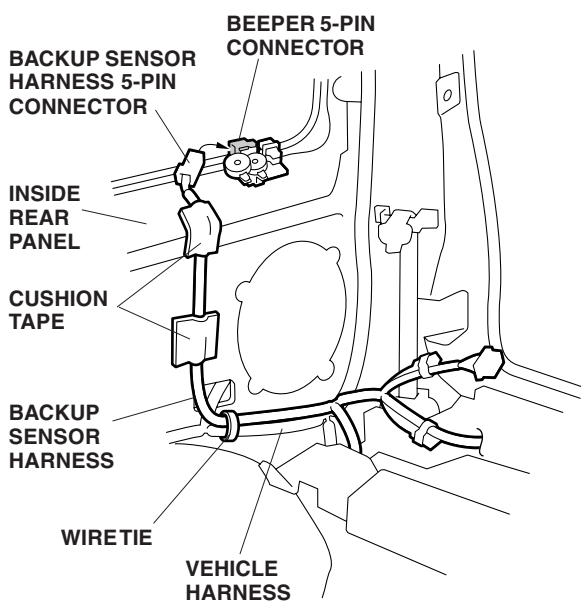

35. Secure the backup sensor harness to the inside rear panel and to the vehicle harness with two cushion tapes and one wire tie in the areas shown. Clean the areas where the cushion tapes will attach with isopropyl alcohol.

36. Using isopropyl alcohol, thoroughly clean the area around the upper hole, then attach the cushion tape to the edge of the upper hole as shown.

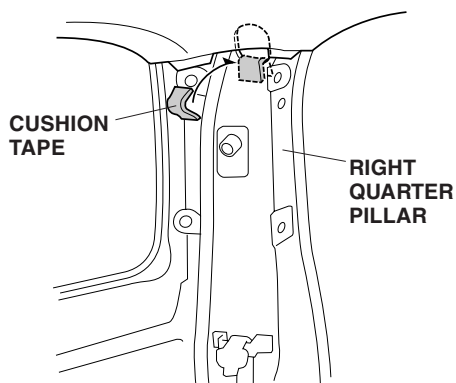

37. Route the 4-pin connector end of the backup sensor harness up along the vehicle harness on the right quarter pillar. Remove the washer hose from the three upper clips. Route the backup sensor harness through the clips, then reinstall the washer hose.

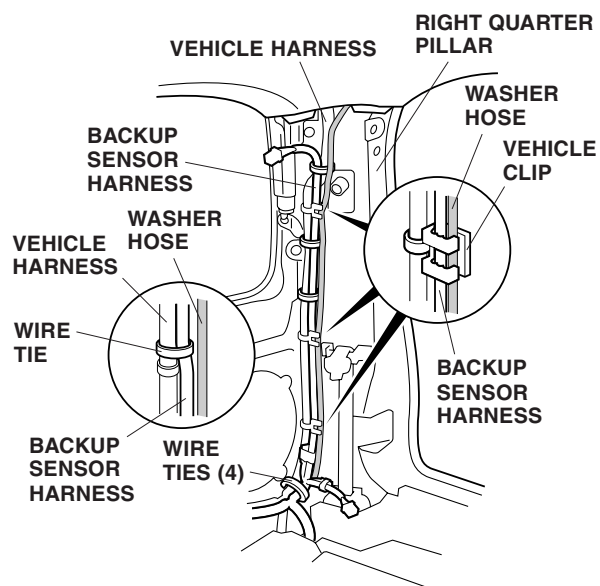

38. Secure the harnesses with four wire ties in the areas shown. Do not attach the wire ties to the washer hose.

39. Attach the backup sensor 2A fuse label to the fuse case on the backup sensor harness.

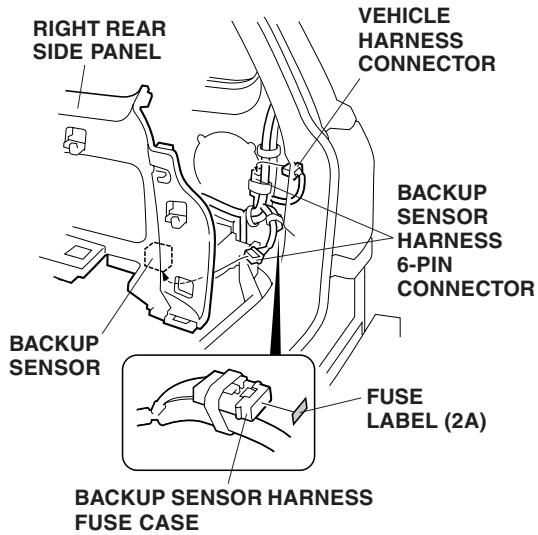

40. Plug the backup sensor harness 6-pin connectors into the sensor on the right rear side panel and into the vehicle 6-pin connector, then reinstall the right rear side panel. Check that all clips and retaining tabs are installed securely.
41. Using a utility knife, cut and remove the rib from the right quarter pillar trim.

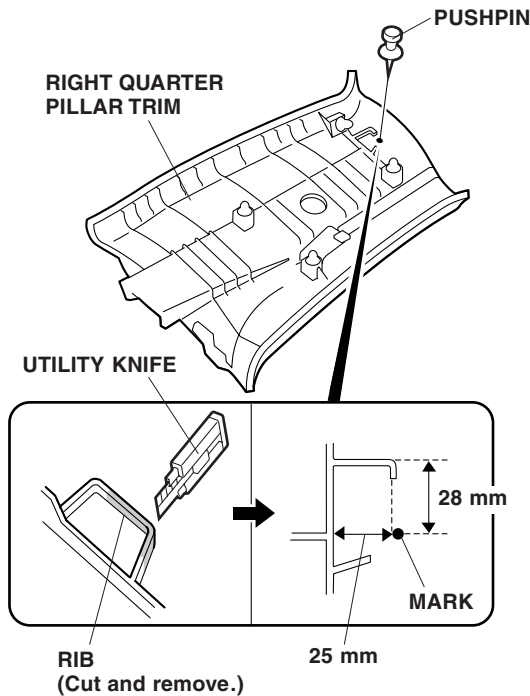

42. Using a pushpin, make a mark on the right quarter pillar trim at the measurement shown.

43. While wearing eye protection, drill a 20 mm hole through the right quarter pillar trim at the mark you made. Remove the burrs from the edge of the hole.

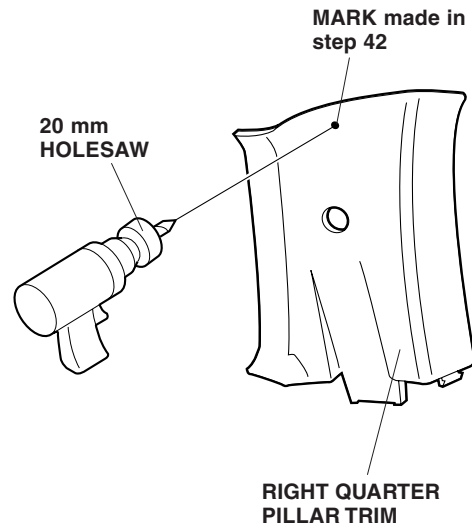

44. Temporarily reinstall the right quarter pillar trim. Mark the roof liner through the hole in the right quarter pillar trim you made using a felt-tip pen.

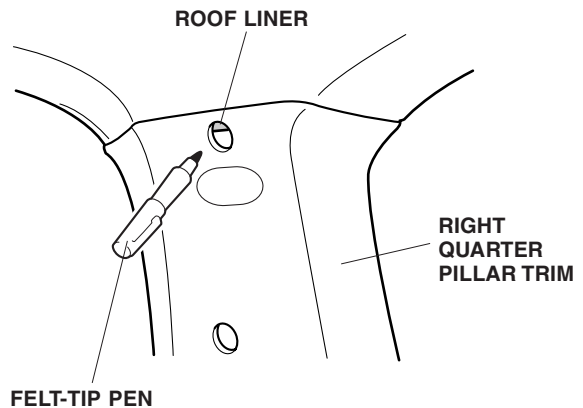

45. Remove the right quarter pillar trim.

46. Using a utility knife, cut the roof liner along the mark you made be careful not to cut the washer hose.

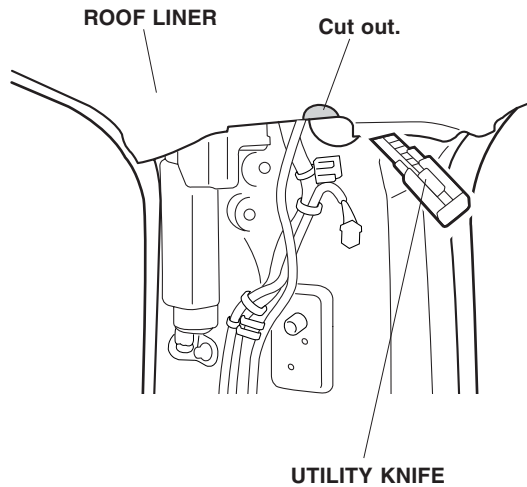

47. Pull the backup sensor harness 4-pin connector out through the 20 mm hole you made, then reinstall the right quarter pillar trim. Check that all clips and retaining tabs are installed securely.

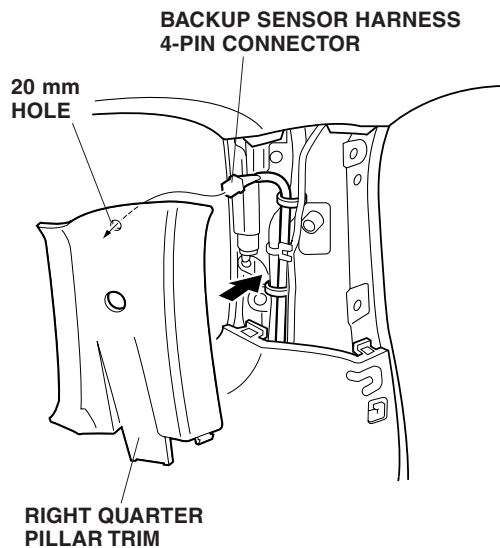

48. Plug the backup sensor harness 4-pin connector into the switch, then install the switch into the hole in the right quarter pillar trim in the direction shown.

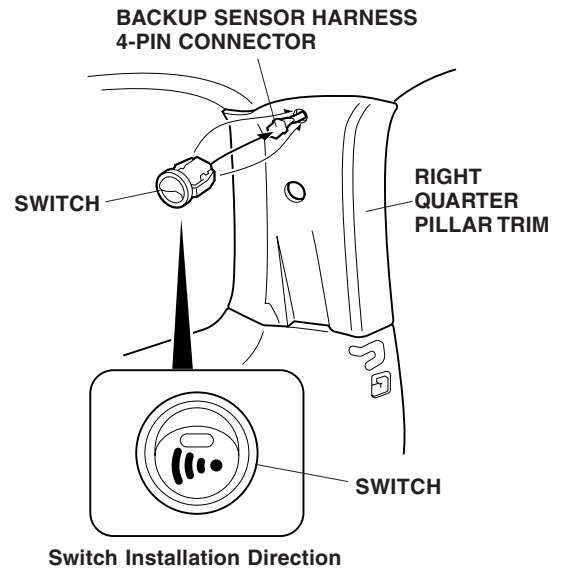

49. Reinstall the rear bumper:
- With the help on a assistant, hold the rear bumper near the vehicle and plug in the two center and the two corner sensor connectors.

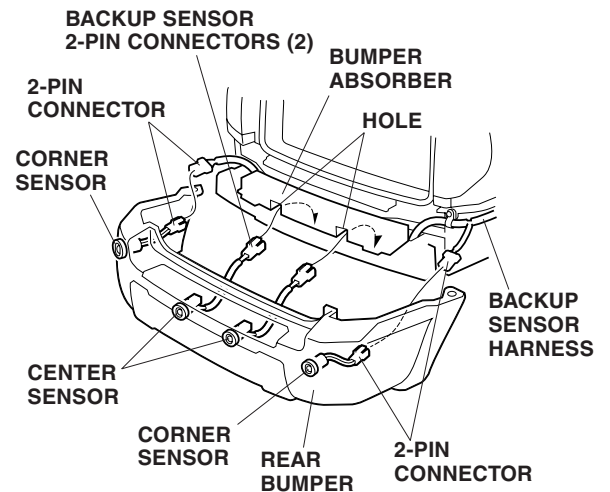

- Reinstall the bumper absorber.
- Route the two center sensor 2-pin connectors through the cut outs in the bumper absorber, and reinstall rear bumper.

50. Secure the center 2-pin connectors to the backup sensor harness with one wire tie for each connector.

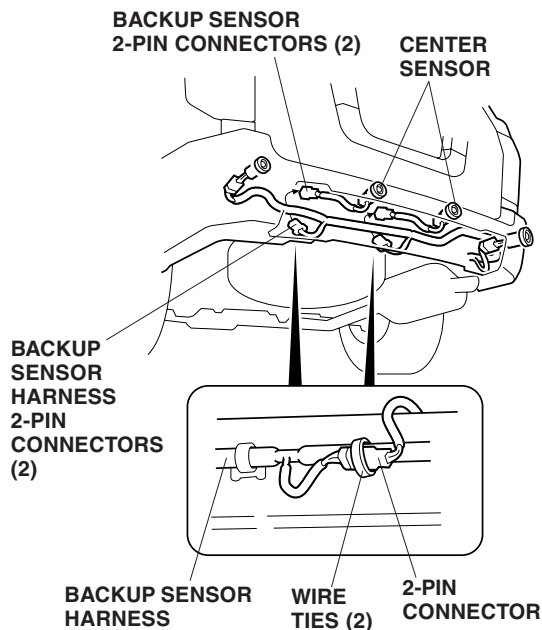

51. Reinstall the rear bumper. Make sure all clips and retaining tabs are installed securely.
52. Check that all wire harnesses and cables are routed properly and that all connectors are plugged in.
53. Reinstall the third seat. Torque the seat bolts to 41 to 53 N·m (30 to 39 lb·ft).
54. Reinstall all removed parts.
55. Reconnect the negative cable to the battery.
56. Enter the customer's radio anti-theft code, and reset the radio station presets.
57. Reset the clock.
58. Check that the backup sensors work properly as described in the Owner's Manual supplied with the backup sensor kit.

NOTE: Whenever the battery is disconnected, the driver's window AUTO function is disabled.
59. Start the engine. Push down on the driver's window switch until the window is fully open.
60. Pull up on the driver's window switch to close the window completely, then hold the switch for 2 seconds.
61. Lower and raise the window to check operation of the driver's window AUTO function.
62. Check that the rear window washer work.